



RB 3200

Light Commercial & Commercial Regulator

The RB 3200 regulator is designed for applications and for all installations with continuous consumption or rapid flow rate variations such as burners, industrial ovens, boilers, etc. It is suitable for installation in cabinets, as a space saving regulator.

KEY BENEFITS

- » Balanced valve design eliminates inlet pressure effect
- » Extra-large capacity
- » Rapid response to load changes
- » Built-in shut-off valve
- » Internal relief
- » Inlet strainer

DESCRIPTION

The RB 3200 model is a direct-acting, spring-loaded regulator (lever type) with a built-in relief valve and optional safety shut-off device.

The balanced valve ensures constant outlet pressure when the upstream pressure varies.

This eliminates changes to the orifice size arising from different inlet pressure ranges.

The regulator is equipped with a built-in filter (filtration grade 0.5 mm).

The safety shut-off valve cuts the gas flow when the outlet pressure exceeds the set pressure (OPSO) or when it drops below the set value (UPSO). It remains closed until the valve is reset manually.

The relief valve avoids triggering the safety shut-off valve in case of thermal expansion, transient surges of pressure, and creep leaks from the regulator. The relief pressure is pre-set at the factory.

Technical Features

Maximum inlet pressure	10 bar
Outlet pressure	7 mbar – 550 mbar
Accuracy & lock-up pressure	Up to AC5 / up to SG10
Operating temperature	-20°C to +60°C
Ambient temperature	-30°C to +60°C (body material)
Acceptable gases	Natural gas, town gas, propane, butane, air, nitrogen or any non-corrosive gas
Installation	Horizontal or vertical
Safety devices	Standard relief valve Optional built-in safety shut-off valve: - over-pressure shut-off (OPSO) - under-pressure shut-off (UPSO)
Sensing line	External

Sizes & Connections

Sizes	1" x 1"½
Type	Parallel internal thread according to ISO 228/1 or ISO 7/1

Materials

Body	Spheroidal graphite iron EN 1563 grade EN-GJS-400-15
Head	Die cast aluminium
Internal parts	Stainless steel and brass
Seals	Nitrile rubber
Diaphragm	Rubberized fabric

Operational Diagram

RBI 3212 Type

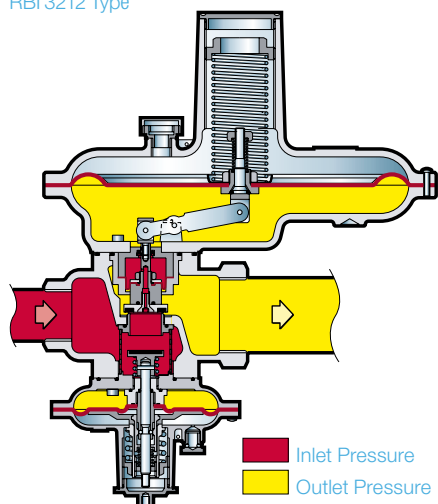

TYPE DESIGNATION AND OPTIONS

To specify the version of the RB 3200 regulator to be ordered, select the options and relevant codes from the table below.

R	B	E	3	2	X	X	Options
						1	LP
						2	MP
						0	Relief valve
						1	Relief valve + over-pressure shut-off valve
						2	Relief valve + over-and under-pressure shut-off valve

Example: RBE3212 is a regulator for LP outlet pressure, with built-in relief valve and over- and under-pressure shut-off valve.

OUTLET PRESSURE RANGE

Regulator

Spring Code	Spring Characteristic				Spring Range	
	d (mm)	De (mm)	Lo (mm)	Lt	LP (mbar)	MP (mbar)
20565166	1.8	35	155	10	7 - 12	•
20565168	2.2	35	155	13	14 - 25	•
20565155	2.7	35	120	11	20 - 50	•
20565156	3	35	120	11.5	28 - 70	•
20565150	3.5	35	100	9.5	20 - 110	•
20565151	4	35	100	10.8	30 - 160	•
955-200-16	4.5	53	207	13	•	100 - 140
955-200-17	5.6	55.1	204	13	•	140 - 300
955-200-78	6.5	55.6	193	11.5	•	300 - 550

Spring characteristics:

d: wire diameter Lo: height
De: external diameter Lt: no. of spires

Safety Shut-off Valves

Over-Pressure Shut-off Springs (OPSO)

Spring Code	Spring Characteristic				Spring Range	
	d (mm)	De (mm)	Lo (mm)	Lt	std (mbar)	High-pressure (mbar)
20563022	1.5	25	35	5.5	28 - 60	•
20563023	1.7	25	35	5.5	45 - 90	90 - 130
20563014	1.9	25	35	5.5	70 - 130	120 - 180
20563124	2.2	25	35	5.5	120 - 220	160 - 330
20563121	2.5	25	35	5.5	220 - 400	300 - 600
20563115	3.0	25	35	5.5	•	580 - 800

* the space available for the OPSO spring is reduced by the UPSO spring assembly

NOTE: The difference between OPSO set point (Pdso) and regulator set point (Pds) should not exceed 350 mbar

Under-Pressure Shut-off Springs (UPSO)

Spring Code	Spring Characteristic				Spring Range	
	d (mm)	De (mm)	Lo (mm)	Lt	std (mbar)	High-pressure (mbar)
20560511	0.8	10	20	7	5 - 28	•
20560518	0.9	10	30	10	27 - 43	•
20560520	1	10.3	25	7.5	30 - 70	•
20560514	1.1	10	24.2	7.8	65 - 105	•
20560517	1.2	10	30	10	100 - 125	50 - 165
20560519	1.4	10	30	10	•	150 - 300

Relief Valve

The built-in relief valve is set 10 mbar (LP) or 45 mbar (MP) above the outlet pressure setting. Other settings on request.

FLOW CAPACITY

RB 3200 with built-in SSV and external sensing line

Inlet Pressure	Capacities in m ³ /h at Standard Conditions							
	Outlet Pressure Setting							
	20 mbar 20565168	50 mbar 20565156	100 mbar 20565150	150 mbar 20565151	200 mbar 955-200-17	300 mbar 955-200-17	350 mbar 955-200-18	450 mbar 955-200-78
0.14 bar	92	91	70	•	•	•	•	•
0.35 bar	160	150	160	150	150	•	•	•
0.5 bar	190	200	190	190	200	190	150	.
0.7 bar	260	250	250	260	260	260	220	200
1 bar	330	330	320	320	300	330	330	270
1.5 bar	390	430	420	420	450	440	440	430
2 bar	530	490	480	520	570	570	530	560
4 bar	900	920	700	790	960	880	940	800
7 bar	1200	1400	830	1200	1500	1300	1500	1500
10 bar	840	1900	890	1000	2200	1900	2200	1600

Maximum capacity at 20% drop, without strainer.

The values given are those for appropriately sized pipe work.

The flow capacities of the regulator without a safety shut-off device are approximately 5% higher.

FLOW CAPACITY

For a 0.6 specific gravity gas, the wide-open orifice flow (Q) may be calculated using the following equations:

- » Sub-critical flow behaviour: where $(P_u - P_d) \leq 0.5 P_u$ $Q = 390 \sqrt{P_d(P_u - P_d)}$
- » Critical flow behaviour: where $(P_u - P_d) > 0.5 P_u$ $Q = 390 P_u / 2$

OVERALL DIMENSIONS (mm)

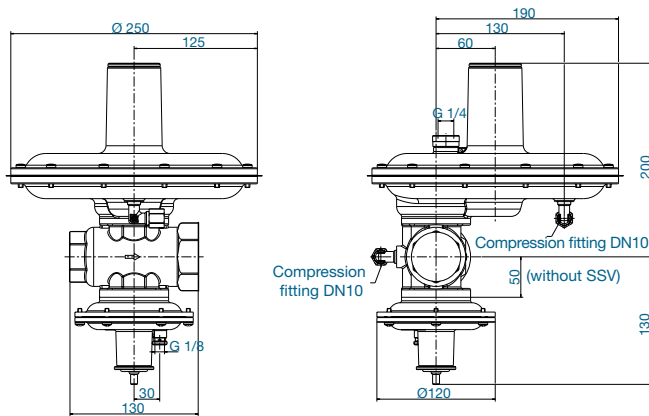

Model RB 3212 - weight: 4.9 kg (4.5 kg without SSV)

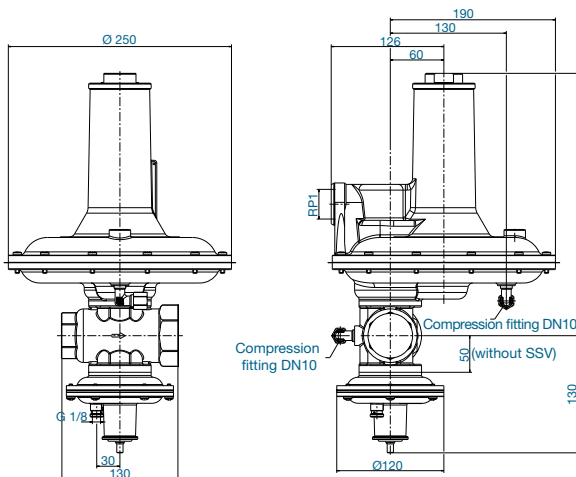

Model RB 3222 - weight: 6.4 kg (6.0 kg without SSV)
Sensing line tapping threaded Rp 1/4" fitted with compression fitting for 10 mm pipe

Standard conditions:

- Absolute pressure of 1.013 bar
- Temperature of 15°C

where:

- Q = volumetric flow rate in m³/h at standard conditions
- P_u = absolute inlet pressure in bar
- P_d = absolute outlet pressure in bar

Correction factor for non-natural gas applications:

The flow rates are indicated for a 0.6 specific gravity gas. To determine the volumetric flow rate for gases other than natural gas, multiply or calculate the values in the capacity tables using the sizing equations with a correction factor.

The table below lists correction factors for some common gases:

Gas type	Specific gravity	Correction factor
Air	1.00	0.77
Butane	2.01	0.55
Carbon dioxide (dry)	1.52	0.63
Carbon monoxide (dry)	0.97	0.79
Natural gas	0.60	1.00
Nitrogen	0.97	0.79
Propane	1.53	0.63
Propane-Air mix	1.20	0.71

Specific gravity or relative density (air = 1, non-dimensional value)

Use the following formula to calculate the correction factor for gases not listed above. In the formula, d is the specific gravity of the gas.

$$\text{Correction factor} = \sqrt{\frac{0.6}{d}}$$

INSTALLATION

The RB 3200 regulator can be mounted in any horizontal or vertical position

- » RB 3200 can be used as a monitor regulator, upstream from an active regulator. In that case, the external sensing line must be connected downstream from the regulator to be controlled.

Information to be specified when ordering:

- » Regulator type code
- » Maximum inlet pressures
- » Outlet pressure range setting
- » Outlet pressure setting
- » Maximum flow rate
 - OPSO setting*
 - UPSO setting*

* (if requested)



Join us in creating a more **resourceful world**.
To learn more visit **itron.com**

While Itron strives to make the content of its marketing materials as timely and accurate as possible, Itron makes no claims, promises, or guarantees about the accuracy, completeness, or adequacy of, and expressly disclaims liability for errors and omissions in, such materials. No warranty of any kind, implied, expressed, or statutory, including but not limited to the warranties of non-infringement of third party rights, title, merchantability, and fitness for a particular purpose, is given with respect to the content of these marketing materials. © Copyright 2014 Itron. All rights reserved. **GA-RB3200-04-EN-06-15**

ITRON GmbH

Hardeckstraße 2
D-76185 Karlsruhe
Germany

Phone: +49 (0) 721 5981 0

Fax: +49 (0) 721 5981 189