

Domusnext® G4

A comprehensive range of *smart and integrated* gas meters
small and easy to install displaying readings
in standard cubic meters,
no external devices needed for conversion and for communication,
for an *accurate billing transparent* to the end customer.



The **G4** meters are available with the following communication technologies:

- Wireless MBUS 169 MHz
- Wireless MBUS 868 MHz
- GPRS

Integrated shut-off valve (optional).
Remotely controllable for end-customer contract management.



MAIN BENEFITS

■ An innovative static measurement principle

Measurement is intrinsically compensated in temperature and independent from pressure. Measurement is displayed directly in standard cubic-meters*.

The measurement technology is based on a MEMS "Micro Thermal Flow Sensing" principle. Two temperature sensors are symmetrically placed around a micro-heating element: under stopped-flow conditions, both sensors measure the same temperature. As the flow rate increases, heat is carried away from the upstream sensor towards the downstream sensor and the measured temperature difference between the two sensors is proportional to the mass flow rate.

■ Transparent billing to the end customer

Memory storage of daily or hourly consumption, with frequent communication of data, means customer invoicing can be transparent and timely, referring to the exact billing period, with low operating costs.

■ Gas recognition

The accuracy of measurement is not affected by changes in the chemical composition of the European distributed gases within the 2nd family groups H and L (as defined by EN 437:2003). By measuring specific gas properties, a pre-set auto-calibration process guarantees the required accuracy levels without any additional adjustment.

The meter is also able to operate in air (test phase), by calibrating itself accordingly without any additional adjustment.

■ Tariff management

Management of 3 tariffs, with consumption divided into 5 daily tariff bands, which can be programmed for weekdays, weekends/public holidays and daylight saving time.

■ Accuracy of measurement at every temperature and at every pressure

Domusnext® meters provide an exact measurement of supplied gas in standard m³, avoiding the use of annual average temperatures and conversion factors, which inevitably lead to approximate values and errors of estimation. These errors then affect the amount billed.

■ Innovation and reliability

Despite being highly innovative, Domusnext® meters have passed the most stringent reliability tests, conducted by notified body and designated laboratories recognised at European level. This certifies the robustness of MeterSit meters and the accuracy of their measurements, even at high concentrations of dust and contaminants in the gas distribution networks. The high accuracy of the measuring principle ensures the gas meter compliance with the MID (Measuring Instruments Directive). Such micro-thermal measuring principle is also commonly used in laboratory instruments. Resistance to contaminants and dust is ensured by design.

■ Connectivity

The application software can be remotely updated or locally updated via optical port in accordance with the EN 62056-21. SIM card is replaceable on location; it is accessible from the battery compartment. The meter is equipped with an Integrated high performance antenna. An external antenna is available on request.

■ Noise level

Thanks to the static technology adopted, the meter has a very low level of noise and practically no wear. This characteristic is well appreciated in particular for domestic application.

* According to UNI EN ISO 13443 standard

Domusnext® G4

Technical data

Type Approval

Measuring range

Standard temperature for volume output

Operating temperature

Standard pressure for volume output

Gas application

Max. operating pressure

Accuracy class

Measuring Accuracy Q_{min} Q_t

Measuring Accuracy Q_t Q_{max}

Max. Pressure drop

Nr. of tariffs

Depth of consumption registers @ 1 day rate

Depth of consumption registers @ 1 hour rate

Nominal Diameter DN

Inlet & Outlet Distance

Width x Height x Depth

Weight

Resistance to water, dust and impact

ATEX

Display

Optical port

Valve

Maximum leakage for the valve

Battery supply

Functioning without external battery

MID T10362 Module B

and CE-193 Module D

0.04 – 6.0 m³/h

15 °C

-25 °C to 55 °C

1013.25 mbar

2nd Family Group H and L (EN 437)

500 mbar

1.5

± 3.0 %

± 1.5 %

<2 mbar at Q_{max}

3

72 days

72 days

G 1 1/4- ISO 228/1

110 mm

192 mm x 137,3 mm x 102 mm

1.7 kg

IP 65, IK 08

zone 2

Ex II 3 G Ex nA IIA T6 Gc

2 lines multi-segment display,

Upper line 10 characters

Lower line 9 digits

Automotive range -30°C to +85°C

EN 62056-21

Compliance with EN 16314

120 cc/h at Pin = 500 mbar

2 x 3.6 V size D lithium cell

(19Ah each)

> 7000h



G4 MBUS



G4 GPRS

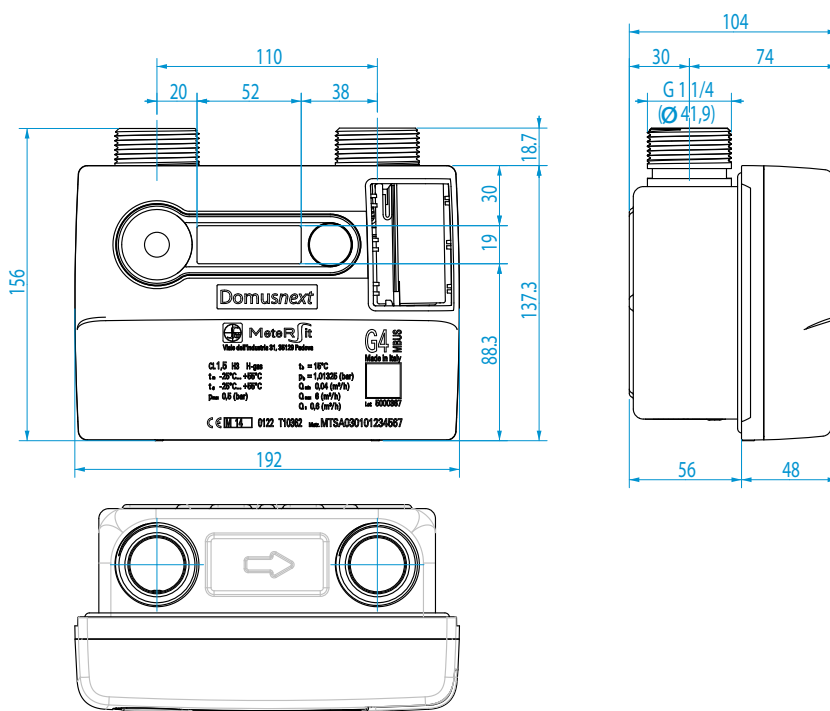
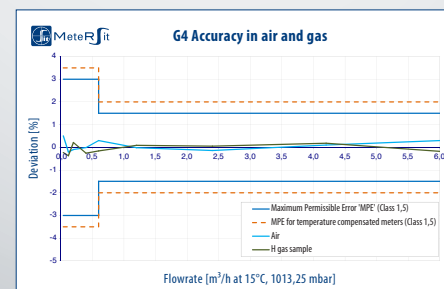

www.metersit.com

Main Office

Via Felice Casati 44 - 20124 Milano

Tel. +39 02 67841211

email: info@metersit.com

Registered Office

Viale dell'Industria 31-33 - 35129 Padova

Tel. +39 049 8293111

Production Plant

Via Achille Grandi 6 - 45100 Rovigo